

GE
Consumer & Industrial

Product description

Digital Energy™ Uninterruptible Power Supply

VH Series UPS

700 - 1000 - 1500 - 2000 - 3000VA



GE imagination at work

CE

Certified
Quality System
ISO 9001
Reg.No.CSQ 9130.GELE

Contents:

1.	Introduction	2
2.	Functional explanation.....	2
2.1	Principles of operation	
2.2	Normal conditions	
2.3	Mains failure	
2.4	Bypass operation	
3.	External description.....	4
3.1	Front and rear panel	
3.2	Enclosure	
3.3	Dimensions	
3.4	Weight	
4.	Electrical specifications.....	5
4.1	Ratings	
4.2	Input converter	
4.3	Output converter	
4.4	Bypass	
4.5	General design criteria	
5.	Performance characteristics.....	6
5.1	Efficiency	
5.2	Environment	
5.3	Runtimes	
5.4	Overload capability	
5.5	Standard features	
6.	Communication ports	8
6.1	USB	
6.2	RJ 11	
7.	Batteries.....	8
8.	Options.....	9
8.1	USB / RS232 / Relay interface card	
8.2	Longer runtimes (VH Series 1000 -3000VA)	
9.	Transport / storage.....	10

© **General Electric**. Data subject to change without prior notice. All brands and product names are Trademarks or Registered Trademarks of their respective owners. Reproduction only upon written consent by GE.

1 - Introduction

The **GE (General Electric) Digital Energy™ VH Series UPS** series is a compact, truly on-line system (VFI, Voltage and Frequency Independent) which incorporates the most advanced power electronics technology to provide exceptional protection for electrical equipment. The VH (Vertical-Horizontal) Series UPS may be used as an upright, floorstanding 'tower' model or mounted in a 19 inch rack. The operating panel can be easily rotated, and all required items for either use (support stands, rackmount brackets) are packed with the UPS.

Each GE Digital Energy UPS is thoroughly tested and conforms within tolerance to the following specifications. (Data are mean values and are subject to change without notice.) Information applies to all models unless otherwise specified.

2 - Functional explanation

2.1 Principles of operation

The UPS stores electric energy in batteries housed in the unit. This allows the UPS to supply output power even when the incoming mains power is cut off completely. Energy is stored as Direct Current (DC), while input and output energy are Alternating Current (AC) in sine wave form. Therefore the UPS contains an input converter (AC to DC) and an output converter (DC to AC) (See fig.1).

The VH Series UPS is a true on line double conversion UPS with:

- a capacitor bank in the DC line
- battery not in line with the DC link, resulting in:
 - enhanced battery life
 - optimal battery charging
- full wave input converter with power factor correction
- extremely wide input voltage and input frequency tolerance
- no inrush current at start up

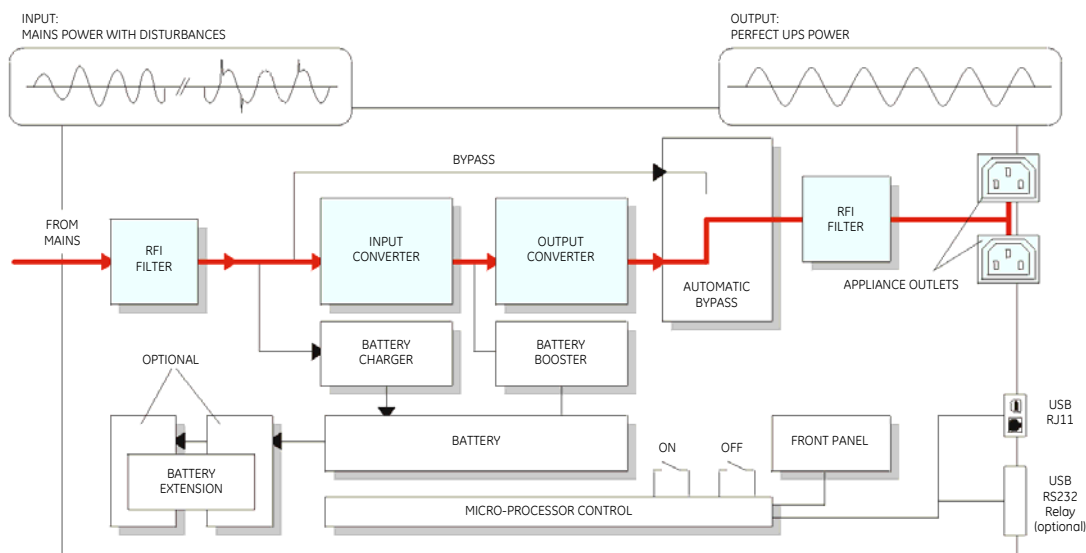

Figure 1 Block diagram of the VH - 700-3000 UPS, mains present

2.2 Normal conditions

Under normal input conditions (see section 4.2) energy from the mains is channeled through the input converter, which supplies the output converter and, together with the battery charger, keeps the battery fully charged. Surges and spikes are blocked completely at the input converter and very unstable mains can be supported. The output converter synthesizes a completely new AC output sine wave to supply the load (electrical equipment).

2.3 Mains failure

In the event of a mains power failure (i.e. mains absent or outside tolerance) the output converter uses the energy reserve stored in the battery to continue to produce AC power, ensuring unbroken output (fig. 2). No interruption or alteration will ever be noticed in the output power.

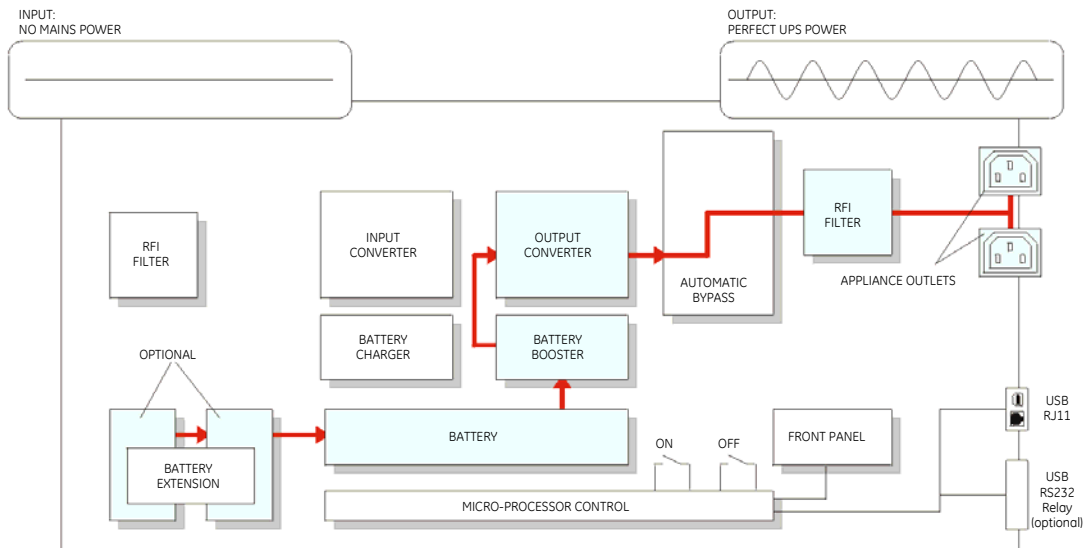

Figure 2 Block diagram of the VH - 700-3000 UPS, mains failure

In the event of an extended mains failure, the output converter will stop when the battery energy has been used up. At this point, the UPS is no longer able to power the connected equipment.

When the mains is re-established within tolerance, the input converter will be supplied again by the mains and the batteries will be recharged, making them ready to support future power failures.

2.4 Bypass operation

If the output converter is unable to deliver the demanded output power (overload, overtemperature) the bypass switch will automatically transfer the load to the mains. If bypass operation is caused by an overload situation, the UPS will try to switch back to output converter after 0.1 seconds, without generating any alarm. This way bypass alarms due to inrush currents, which normally last less than 0.1 seconds, are avoided. If the overload situation still exists after three switch-back attempts (i.e. the overload is not caused by inrush currents), the unit will remain in bypass mode, generating a bypass alarm. It will switch back to output converter when the overload has been removed. If bypass operation is caused by overtemperature, the unit will switch back when the temperature has dropped below alarm level. When the normal situation is restored, the load will be transferred back to the output converter.

The transfer time is typically less than 1 msec and is sufficiently short for modern computers, which can ride through 10-20 milliseconds.

If a power failure occurs during bypass operation, the UPS will switch back to inverter and eventually, when the batteries are depleted, output power is lost. If the UPS functions under overload conditions it may not be able to protect the load.

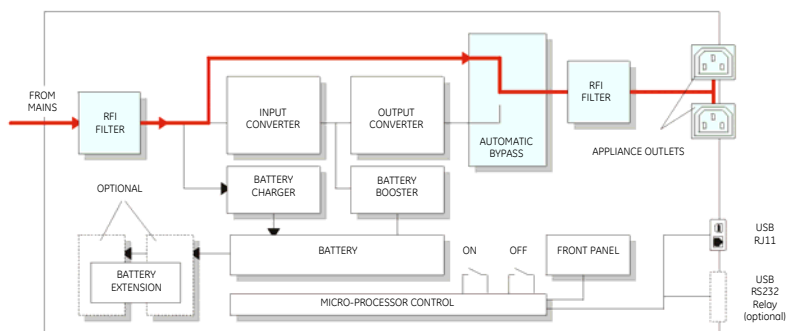

Figure 3 Bypass operation

3 - External description

3.1 Front and rear panel

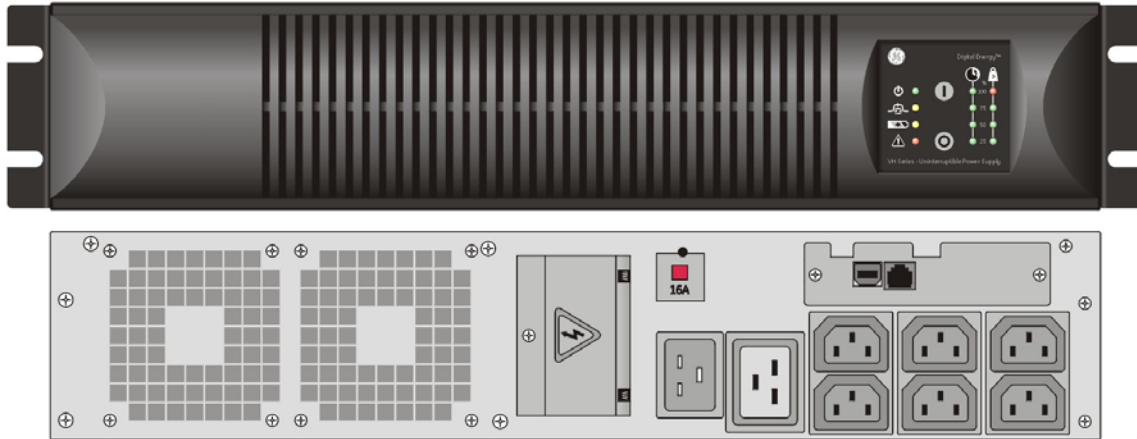

Figure 4 Front and rear panel VHSeries 3000, rackmount orientation

FRONT

Operation	: green LED
On bypass	: yellow LED
On battery	: yellow LED
Alarm	: red LED
Runtime capacity	: LED bar
Load	: LED bar
Push-buttons 'on' and 'off'	

REAR

Input socket	: IEC 320 C14 male
Input fuse	: TCB (thermal circuit breaker)
Output sockets	: IEC 320 C13 female IEC 320 C20 fem (VH 3000)
DC connector	: not on VH 700
USB Port	
RJ11 Port	
Fans	: electronically controlled

3.2 Enclosure

Construction	: steel/plastic
Colour	: RAL 9005 (black)
Protection	: IP 20

VH Series model	:	700	1000	1500	2000	3000
------------------------	----------	------------	-------------	-------------	-------------	-------------

3.3 Dimensions

Dimensions UPS tower (h _x w _x d, mm)	:	440x87x472	440x87x547
Shipping dimensions (h _x w _x d, mm)	:	205x545x540	205x545x655
Dimension battery pack (h _x w _x d, mm)	:	36Vdc: 440x87x472; 72Vdc: 440x87x547	
Shipping dims batt. pack (h _x w _x d, mm)	:	36Vdc: 205x545x540; 72Vdc: 205x545x655	

3.4 Weight

Weight UPS (kg)	:	18.3	18.3	19.3	31.1	33.1
Weight 36V / 72V battery pack (kg)	:	29 / 47				
Shipping weight UPS (kg)	:	21.6	21.6	22.6	34.8	36.8
Shipping weight 36V / 72V batt. pack (kg)	:	32.3 / 50.7				

4 - Electrical specifications

4.1 Ratings

VH Series model	:	700	1000	1500	2000	3000
Voltage Amperes (VA) with computer type load	:	700	1000	1500	2000	3000
Watts (W) with resistive load	:	490	700	1050	1400	2100
Input thermal circuit breaker (A)	:	7	7	8	10	16
Input fuses (A)	:	8	8	10	16	20

4.2 Input converter

AC input voltage	:	220 - 240 V				
AC input voltage range	:	160 - 280 V				
at 100% load	:	160 - 280 V				
at 70% load	:	130 - 280 V				
Minimum start-up AC voltage	:	170 V (at any load)				
High voltage protection	:	above 280Vac the UPS will disconnect the mains and switch to battery operation				
Input current (A), at nominal input voltage	:	3.0	4.4	6.4	8.8	11.1
Input current waveform	:	sinusoidal, conform or better than EN 61000-3-2 (IEC 555-2)				
Input power factor	:	1				
Input frequency range	:	45 - 66 Hz				
Inrush current	:	none				

4.3 Output converter

AC output voltage	:	220 / 230 / 240 V (selectable)				
AC output voltage tolerance	:	± 2% (static and dynamic)				
Output frequency	:	50 or 60 Hz (front selectable)				
Output frequency range	:	nominal ± 0.15% unless synchronized to the mains				
Output waveform	:	sine wave				
Harmonic distortion	:	< 2% (typical 1%) with linear load				
Power factor	:	0.7				
Crest factor (peak to RMS current):	:	up to 6:1				
Capacity appliance outlets	:	max. 10 A per outlet (one 16A outlet on VH 3000 VA)				

4.4 Bypass

AC input voltage range	:	selected output voltage +15% -10%				
Frequency tracking rate	:	2 Hz/sec.				
Frequency tracking range	:	nominal ± 10%				
Phase difference	:	< 7°				
Transfer time, msec	:	1				

4.5 General design criteria

Safety	:	EN 62040-1-1 (EN 60950)				
Electromagnetic compatibility	:	EN 62040-2				

Note: The VH Series UPS is intended for use in normal domestic and office situations (see Safety: EN 62040-1-1)

5 - Performance characteristics

VH Series model : **700** **1000** **1500** **2000** **3000**

5.1 Efficiency (battery fully charged)

Efficiency (%) on mains

- 20% load	:	72	75	81	79	85
- 50% load	:	82	86	89	88	89
- 100% load	:	87	89	90	91	91

Efficiency (%) on battery (at nominal battery voltage)

- 20% load	:	72	76	80	82	84
- 50% load	:	82	82	85	85	86
- 100% load	:	84	84	86	87	88

5.2 Environment

Ambient temperature	:	-10 to +40°C
Audible noise at 1 meter	:	< 45dB(A), load and temperature dependent
Max. relative humidity	:	95% (non-condensing)

5.3 Runtimes (ratings given for 25°C)

VA / Watts	runtime in minutes				
At typical UPS load (75%)	16	11	8	11	8
100 / 70	120	120	180	>180	>180
300 / 210	32	32	40	60	75
700 / 490	13	13	16	30	35
1000 / 700	-	8	10	20	20
1500 / 1050	-	-	6	11	16
2000 / 1400	-	-	-	8	10
3000 / 2100	-	-	-	-	6

VH Series 1000-3000 VA units connected to battery cabinets will have longer runtimes. See section 8.2.

5.4 Overload capability

Overload protection	:	Fully protected against overload and short circuits.
Overload behaviour:	:	
- battery operation	:	110% during 5 minutes, 150% during 2 seconds
- bypass operation	:	depends on rating of thermal circuit breaker; typical 125% of TCB value: for 200 seconds 200% of TCB value: for 10 seconds 300% of TCB value: for 4 seconds

5.5 Standard features

Wide AC input voltage window

Minimises need for battery operation

High voltage protection

Above the maximum input voltage (280Vac), the VH Series UPS will protect itself and the load by disconnecting the mains and switching to battery operation. Reducing the mains voltage will recover the normal situation. If the mains voltage rises above 312Vac the UPS shuts down immediately and must be restarted manually.

Power factor one input

The AC input current drawn by the UPS is less than that supplied to the load. Contrary to UPS and computers without this feature, no disturbances which may cause problems to other electrical equipment are fed back to the mains. This feature will become mandatory within a few years.

Bypass operation enable/disable

In case of an unstable bypass voltage and/or frequency you may not wish the load to be transferred to the bypass. Front selectable.

No UPS inrush current

When switching on, the UPS causes no inrush current. Inrush currents result in voltage dips on the mains which can disturb other equipment or even blow the fuse of the distribution board.

No load inrush current (Softstart of the connected load)

Also when switching on, the bypass is disabled for a short while, avoiding high inrush currents of the load through the bypass, which also can cause the distribution fuse to trip.

Battery start (cold start)

Allows you to switch on the unit while the mains input is absent.

Superior battery management for maximum battery life and reliability:

- **Automatic (quick) battery test**
The VH Series UPS conducts automatic battery tests to ensure that the batteries and the wiring are healthy and able to support power failures. The tests are executed 5 hours after starting up or return of mains, and every 30 days. The tests can also be initiated via the front panel and through UPS monitoring software.
- **Deep battery calibration test**
The actual battery capacity can be tested by the UPS monitoring software, ensuring accurate runtime prediction. During a deep battery test the batteries will be discharged until 'battery low' alarm level. Please refer to the manual of the appropriate monitoring software package.
- **Temperature compensated battery charging**
This feature reduces the battery charge voltage with increasing temperature. As a result poor charging of the batteries under low temperature conditions and overcharging of the batteries under high temperature conditions are prevented.
- **Load dependent battery-end voltage**
The allowable final battery voltage depends on the discharge current: the higher the current, the lower the 'end-of-discharge' battery voltage. This gives maximum capacity without overdischarging. Overdischarging results in failure to recover normal capacity and in shortened battery life.
- **Automatic boost charge**
Reduces the recharge time to 1.5 hours for approx. 90% capacity without overcharging the batteries.
- **No-load shutdown**
Whenever a load of <5% of the UPS maximum load is registered and no mains power is present, the UPS will switch off automatically. Load sensing during battery mode prevents unnecessary discharging of the batteries. The function is default activated (front selectable) to avoid accidentally switching on during transport.

6 - Communication ports

6.1 USB

The USB port is a plug-in interface port which enables advanced communication between the UPS and the computer (UPS software required). The interface port is operative as soon as the mains power cord is plugged into a live wall outlet, even if the UPS is switched off.

For more information please refer to the user manual that comes with the interface software. We strongly recommend to use only original GE Digital Energy software products in combination with the interface port.

6.2 RJ 11 port

The RJ 11 port is a plug-in contact interface port.

Pin #	Function
1	Mains failure
2	General alarm ¹⁾
3	Battery low
4	On bypass
5	Remote UPS shutdown
6	GND

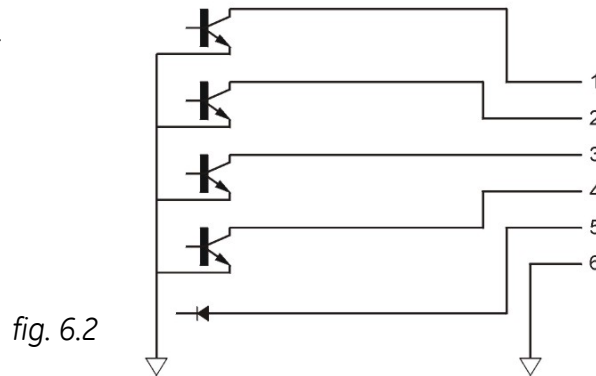

1)

Active if the output voltage of the UPS is no longer guaranteed due to other circumstances than already indicated by pin 1-3-4:

- General fault
- Overload
- Overtemperature
- Output out of tolerance
- Charger failure
- Bypass out of limits
- Replace battery

7 - Batteries (ratings given for 25°C)

VH Series model	: 700	1000	1500	2000	3000
Nominal voltage (V)	: 36	36	36	72	72
Number / Ah batteries	: 3 / 7	3 / 7	3 / 9	6 / 7	6 / 9
Type	: sealed and maintenance free				
Service life	: up to 6 years (depending on operating conditions)				
Runtime	: see section 5.3, Runtimes				
Battery recharge current	: 1.7 A				
Battery recharge time	: 1.5 hours for 90% capacity				
Automatic (quick) battery test	: 5 hrs after return of mains, 5 hrs after manual switch on, and 30 days from last battery test				

Long term storage: see chapter 9.

8 - Options

8.1 USB / RS232 / Relay interface card

The card is equipped with

- USB port as described in 6.1
- RS232 port
- potential free change-over relay contacts for the following alarms:
 - mains failure
 - general alarm
 - battery low
 - bypass active

8.2 Longer runtimes (VH Series 1000 - 3000 VA)

By adding extra battery packs the runtime of the VH Series UPS models 1000-3000VA can be extended.

Battery packs are available in 36V/14Ah (for VH 1000-1500) and 72V/14Ah (for VH 2000-3000).

The battery pack has the same dimensions as the UPS 1000-1500 VA models (see 3.3) and in case of floor-standing use one battery pack can be mounted together with the UPS in one set of support stands.

	Battery extension voltage/capacity V/Ah	total capacity Ah	typical runtime 100% / 50% load minutes
1000VA			
std. UPS	36 / 7	7	7 / 18
1 pack:	36 / 14	21	32 / 70
2 packs:	36 / 14+14	35	59 / 97
1500VA			
std. UPS	36 / 9	9	6 / 15
1 pack:	36 / 14	23	21 / 54
2 packs:	36 / 14+14	37	41 / 76
2000VA			
std. UPS	72 / 7	7	7 / 18
1 pack:	72 / 14	21	32 / 70
2 packs:	72 / 14+14	35	59 / 97
3000VA			
std. UPS	72 / 9	9	6 / 15
1 pack:	72 / 14	23	21 / 54
2 packs:	72 / 14+14	37	41 / 76

9 - Transport / storage

No liability can be accepted for any transport damage when the equipment is shipped in non-original packaging.

Store the UPS in a dry location with the batteries in a fully charged state.

Storage temperature must be within -20 +45 °C. If the unit is stored for a period exceeding 3 months, optimal battery lifetime is obtained if the storage temperature does not exceed 25°C.

If the unit is stored for an extended period of time, the batteries must be recharged periodically. Be sure that the batteries are connected to the UPS. Subsequently connect the unit to a wall outlet and recharge the batteries for 24 hours:

- if the storage temperature is within -20 and +30°C: every 3 months,
- if the storage temperature is within -20 and +45°C: every month.

A product by:

GE Consumer & Industrial SA
General Electric Company
CH – 6595 Riazzino (Locarno)
Switzerland
T +41 (0)91 / 850 51 51
F +41 (0)91 / 850 51 44
E gedeinfo@ge.com

www.gedigitalenergy.com